

## DUCT FANS



# BSKF-R

AC DIRECT DRIVE RECTANGULAR IN LINE  
DUCT FANS  
Forward Curved

120°C

### Technical Drawings

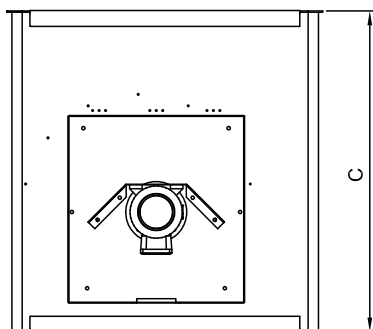
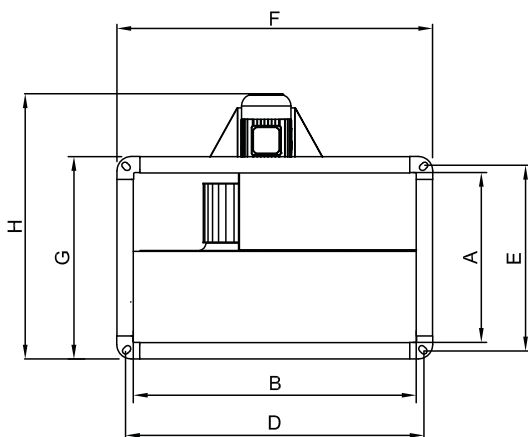

#### MATERIAL

: Housing is made of galvanized sheet metal.  
Impeller is forward curved.

#### INSULATION CLASS

: Class F

#### DIRECTIVE

: EN 60335-1, EN 60335-2-80

#### SPEED CONTROL

: Speed can be adjusted using an optional controller.

#### APPLICATION AREAS

: Kitchen exhaust, hotels, autoparks, buildings, shopping centers etc.

TYPE	A	B	C	D	E	F	G	H
BSKF-R 200	200	400	500	420	220	450	250	469
BSKF-R 225	250	500	560	520	270	550	300	519
BSKF-R 250	300	500	560	520	320	550	350	589
BSKF-R 280	300	600	710	620	320	650	350	589
BSKF-R 315	350	600	710	620	370	650	400	684
BSKF-R 355	400	700	780	720	420	750	450	766
BSKF-R 400	500	800	880	820	520	850	550	866
BSKF-R 450	500	1000	980	1020	520	1050	550	886

Dimensions are in (mm)

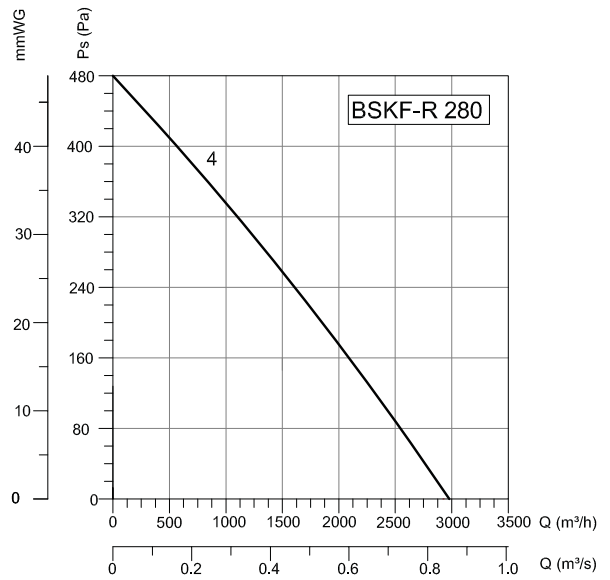
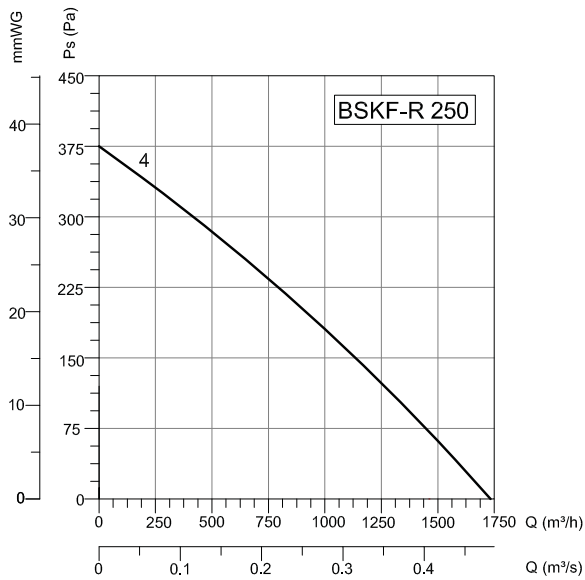
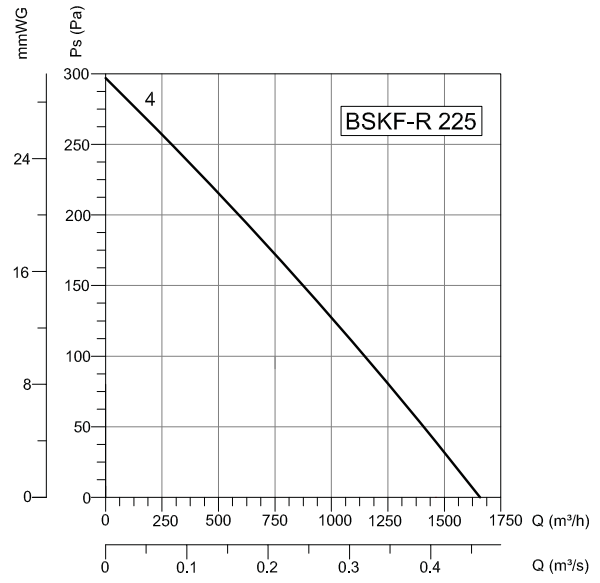
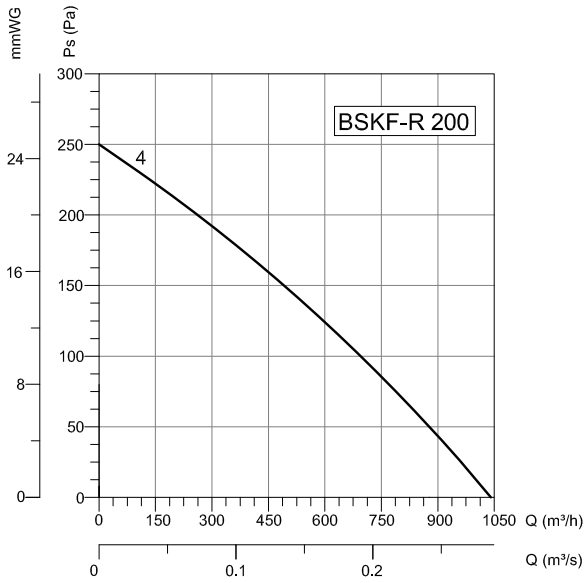

TYPE	VOLTAGE	FREQUENCY	POWER	CURRENT	SPEED	AIR FLOW	WEIGHT
	V	Hz	Kw	(A)	d/d	m <sup>3</sup> /h	kg
BSKF-R 200-4	230/380	50	0,25	1,8/0,81	1400	1000	22
BSKF-R 225-4	230/380	50	0,37	2,6/1,15	1400	1673	35
BSKF-R 250-4	230/380	50	0,55	3,3/1,5	1400	1740	40
BSKF-R 280-4	230/380	50	0,75	4,6/2	1400	2942	43
BSKF-R 315-4	230/380	50	1,5	9,3/3,5	1400	4050	55
BSKF-R 315-6	380	50	0,37	1,1	900	2650	52
BSKF-R 355-4	230/380	50	2,2	13,4/5,1	1400	8000	85
BSKF-R 355-6	380	50	1,1	3	900	5200	81
BSKF-R 400-6	380	50	1,5	3,5	900	6000	92
BSKF-R 450-6	380	50	2,2	5,1	900	7500	120

# DUCT FANS

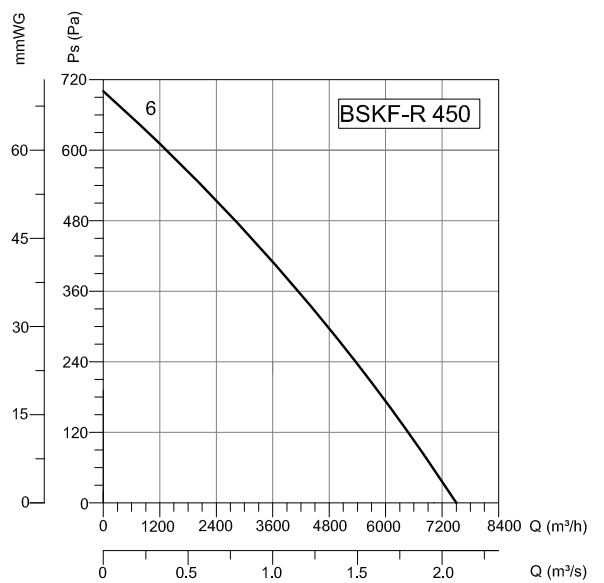
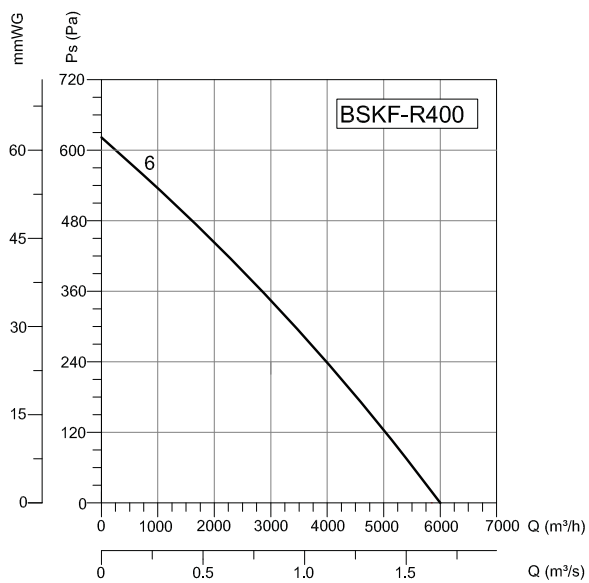
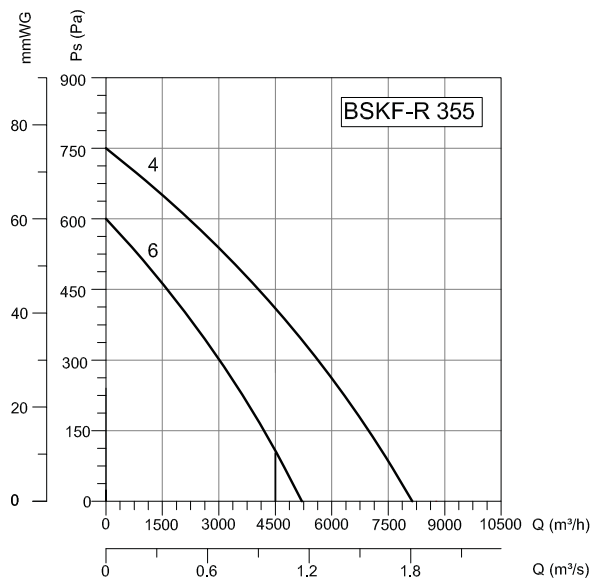
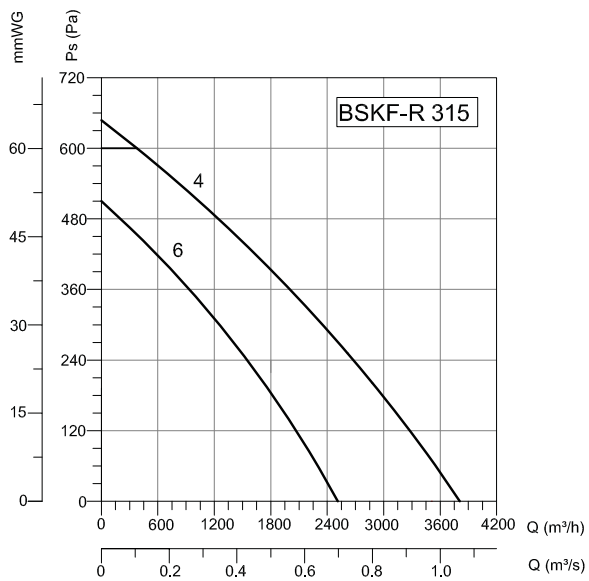

## Accessories



**BSC**



**BSC-F**



**BDEB**

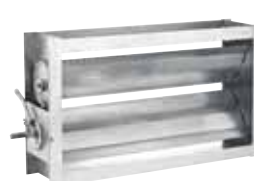

**BDH**



**BDKS**